

About this Manual

We've added this manual to the Agilent website in an effort to help you support your product. This manual is the best copy we could find; it may be incomplete or contain dated information. If we find a more recent copy in the future, we will add it to the Agilent website.

Support for Your Product

Agilent no longer sells or supports this product. Our service centers may be able to perform calibration if no repair parts are needed, but no other support from Agilent is available. You will find any other available product information on the Agilent Test & Measurement website, www.tm.agilent.com.

HP References in this Manual

This manual may contain references to HP or Hewlett-Packard. Please note that Hewlett-Packard's former test and measurement, semiconductor products and chemical analysis businesses are now part of Agilent Technologies. We have made no changes to this manual copy. In other documentation, to reduce potential confusion, the only change to product numbers and names has been in the company name prefix: where a product number/name was HP XXXX the current name/number is now Agilent XXXX. For example, model number HP8648A is now model number Agilent 8648A.

Your Comments Please

HP E2423A

Your comments assist us in meeting your needs better. Please complete this questionnaire and return it to us. Feel free to add any additional comments that you might have. All comments and suggestions become the property of Hewlett-Packard. Omit any questions that you feel would be proprietary.

- | | Yes | No |
|---|-----|-----|
| 1. Did you receive your product when expected? | [] | [] |
| 2. Were you satisfied with the operation of the preprocessor interface at turn-on? | [] | [] |
| 3. Were the proper accessories supplied with your product?
If not, what was missing?
Cable(s) [] Manual(s) [] Other _____ | | |

4. What measurements will this preprocessor interface be used to make?:

5. Which logic analyzer are you using?:
Type _____

6. What do you like most about the preprocessor interface?:

7. What would you like to see changed or improved? _____

8. Which sections of the manual have you used?
- Installation Overview
 - Step-By-Step Procedures
 - Specifications
 - Schematics and Parts List

9. Please rate the manual on the following:
- 4= Excellent 3= Good 2= Adequate 1= Poor
- Breadth and depth of information
 - Ability to easily find information
 - Ability to understand and apply the information provided in the manual

Please explain: _____

10. What is your experience with logic analyzers and preprocessor interfaces?
- No previous experience
 - Less than 1 year experience
 - More than 1 year's experience on one model
 - More than 1 year's experience on several models
- Name _____ Company _____
Address _____ Zip Code _____
Phone _____ Instrument Serial # _____

THANK YOU FOR YOUR HELP

NO POSTAGE NECESSARY IF MAILED IN U.S.A.

Herstellerbescheinigung

Hiermit wird bescheinigt, daß das Gerät/System

HP 1650A/B and HP 1651A/B

in Übereinstimmung mit den Bestimmungen von Postverfügung 1046/84 funkentstört ist.

Der Deutschen Bundespost wurde das Inverkehrbringen dieses Gerätes/Systems angezeigt und die Berechtigung zur Überprüfung der Serie auf Einhaltung der Bestimmungen eingeräumt.

Zusatzinformation für Meß- und Testgeräte

Werden Meß- und Testgeräte mit ungeschirmten Kabeln und/oder in offenen Meßaufbauten verwendet, so ist vom Betreiber sicherzustellen, daß die Funk-Entstörbestimmungen unter Betriebsbedingungen an seiner Grundstücksgrenze eingehalten werden.

Manufacturer's declaration

This is to certify that this product HP 1650A/B and HP 1651A/B meets the radio frequency interference requirements of directive Vfg. 1046/84. The German Bundespost has been notified that this equipment was put into circulation and was granted the right to check the product type for compliance with these requirements.

Additional Information for Test- and Measurement Equipment

Note: If test and measurement equipment is operated with unshielded cables and/or used for measurements on open set-ups, the user must insure that under these operating conditions, the radio frequency interference limits are met at the border of his premises.

Note: This declaration indicates compliance of this product with the German RFI specifications stated in the German Vfg. 1046/84 directive.

HP E2423A

SCSI Bus Preprocessor Interface

User's Guide

for the HP 1650A, HP 1650B, HP 1652B, HP 1660A/61A/62A/63A,
HP 16510A, HP 16510B, HP 16511B, HP 16540/16541A,D, HP 16542A, and
HP 16550A Logic Analyzers



Copyright Hewlett Packard Company 1992

Manual Part Number E2423-90904
Microfiche Part Number E2423-90804

Printed in U.S.A. November 1992

Printing History

New editions are complete revisions of the manual. Update packages, which are issued between editions, contain additional and replacement pages to be merged into the manual by the customer. The dates on the title page change only when a new edition is published.

A software code may be printed before the date; this indicates the version of the software product at the time the manual or update was issued. Many product updates and fixes do not require manual changes and, conversely, manual corrections may be done without accompanying product changes. Therefore, do not expect a one to one correspondence between product updates and manual updates.

Edition 1

November 1992

E2423-90904

List of Effective Pages

The List of Effective Pages gives the date of the current edition and of any pages changed in updates to that edition. Within the manual, any page changed since the last edition is indicated by printing the date the changes were made on the bottom of the page. If an update is incorporated when a new edition of the manual is printed, the change dates are removed from the bottom of the pages and the new edition date is listed in the Printing History and on the title page.

Pages

Effective Date

Product Warranty

This Hewlett-Packard product has a warranty against defects in material and workmanship for a period of 1 year from date of shipment. During warranty period, Hewlett-Packard Company will, at its option, either repair or replace products that prove to be defective.

For warranty service or repair, this product must be returned to a service facility designated by Hewlett-Packard. However, warranty service for products installed by Hewlett-Packard and certain other products designated by Hewlett-Packard will be performed at Buyer's facility at no charge within the Hewlett-Packard service travel area. Outside Hewlett-Packard service travel areas, warranty service will be performed at Buyer's facility only upon Hewlett-Packard's prior agreement and Buyer shall pay Hewlett-Packard's round trip travel expenses.

For products returned to Hewlett-Packard for warranty service, the Buyer shall prepay shipping charges to Hewlett-Packard and Hewlett-Packard shall pay shipping charges to return the product to the Buyer. However, the Buyer shall pay all shipping charges, duties, and taxes for products returned to Hewlett-Packard from another country.

Hewlett-Packard warrants that its software and firmware designated by Hewlett-Packard for use with an instrument will execute its programming instructions when properly installed on that instrument. Hewlett-Packard does not warrant that the operation of the instrument, software, or firmware will be uninterrupted or error-free.

Limitation of Warranty The foregoing warranty shall not apply to defects resulting from improper or inadequate maintenance by the Buyer, Buyer-supplied software or interfacing, unauthorized modification or misuse, operation outside of the environmental specifications for the product, or improper site preparation or maintenance.

NO OTHER WARRANTY IS EXPRESSED OR IMPLIED.
HEWLETT-PACKARD SPECIFICALLY DISCLAIMS THE
IMPLIED WARRANTIES OF MERCHANTABILITY AND FITNESS
FOR A PARTICULAR PURPOSE.

Exclusive Remedies THE REMEDIES PROVIDED HEREIN ARE BUYER'S SOLE AND EXCLUSIVE REMEDIES. HEWLETT-PACKARD SHALL NOT BE LIABLE FOR ANY DIRECT, INDIRECT, SPECIAL, INCIDENTAL, OR CONSEQUENTIAL DAMAGES, WHETHER BASED ON CONTRACT, TORT, OR ANY OTHER LEGAL THEORY.

Assistance Product maintenance agreements and other customer assistance agreements are available for Hewlett-Packard products.

For assistance, contact your nearest Hewlett-Packard Sales and Service Office.

Certification Hewlett-Packard Company certifies that this product met its published specifications at the time of shipment from the factory. Hewlett-Packard further certifies that its calibration measurements are traceable to the United States National Bureau of Standards, to the extent allowed by the Bureau's calibration facility, and to the calibration facilities of other International Standards Organization members.

Safety This product has been designed and tested according to International Safety Requirements. To ensure safe operation and to keep the product safe, the information, cautions, and warnings in this user's guide must be heeded.

Table of Contents

Introduction

Logic Analyzers Supported
How to Use This Manual

Chapter 1:

Setting Up the HP E2423A

Introduction	1-1
Duplicating the Master Disk	1-1
HP 16500A Software Compatibility	1-1
Equipment Supplied	1-1
Equipment Required	1-2
Installation Quick Reference	1-2
Setting Up the HP E2423A Front Panel.	1-3
Connecting the HP E2423A to the SCSI Bus.	1-4
Connecting to the HP E2423A.	1-6
Power Up / Down Sequence	1-6
Setting Up the Analyzer from the Disk.	1-10
Loading an Inverse Assembler.	1-11
Selecting the Correct Inverse Assembler	1-12

Chapter 2:

Analyzing the SCSI Bus

Introduction	2-1
Format Specification	2-1
Symbols and Labels	2-2
Accumulating Data	2-6
Listing Menu	2-6
The SCSI Bus Inverse Assemblers	2-7
Interpreting Commands.	2-8
Interpreting Vendor Unique and Reserved Information	2-8
Interpreting Messages	2-9
Interpreting Status	2-10
Interpreting Data	2-11
Arbitration, Select, and Reselect Phases.	2-11
Attention, Reset and Bus Free	2-11
Parity Error	2-11
The Trace Menu	2-12
LED Indicators	2-13

Chapter 3:**Additional Information**

Introduction	3-1
Characteristics	3-1
Clocking	3-3
Interface Description	3-6
SCSI Bus Signal to HP E2423A Connector Mapping	3-7
Servicing	3-11

Appendix A:**SCSI Overview**

Introduction	A-1
SCSI Status Lines	A-2

Appendix B:**Troubleshooting**

"Slow or Missing Clock"	B-1
No Activity on Activity Indicators	B-1
Slow Clock	B-2
"No Configuration File Loaded"	B-2
"Selected File is Incompatible"	B-2
". . . Inverse Assembler Not Found"	B-3
No Inverse Assembly	B-3
Incorrect Inverse Assembly	B-3
"State Clock Violates Overdrive Specification"	B-3
Unwanted Triggers	B-3
"Waiting for Trigger"	B-4
Intermittent Data Errors	B-4
Bent Pins	B-4
"Time from Arm Greater Than 41.93 ms."	B-4
No Setup/Hold Field on Format Screen	B-4
"Default Calibration Factors Loaded" (16540/41/42)	B-4

Introduction

The HP E2423A Small Computer Systems Interface (SCSI) Bus Preprocessor Interface provides a complete mechanical and electrical connection between an 8-bit or 16-bit Single-Ended or Differential SCSI Bus system and a variety of HP logic analyzers. Switches on the front panel allow you to select the appropriate bus type, bus size, and parity. LED lights as indicators allow you to look at the static condition of the bus at a quick glance. The HP E2423A software provides inverse assembly of activity on the buses, and configurations for the logic analyzers.

Logic Analyzers Supported

The following logic analyzers are supported by the HP E2423A Preprocessor Interface:

HP 1650A (requires memory upgrade)

This logic analyzer provides 1 k of memory depth with either 80 channels of 25 MHz state analysis or 80 channels of 100 MHz timing analysis.

Due to the memory requirements for the HP E2423A inverse assemblers, the HP 1650A Logic Analyzer requires a memory upgrade to work with the HP E2423A Preprocessor Interface. To increase the amount of memory in your HP 1650A you must install the 10449A memory upgrade. For more information contact your Hewlett-Packard Sales/Service Office.

Notice that the 10449A memory upgrade only increases the inverse assembler processing space. It does not increase the 1 k state memory depth.

HP 1650B, HP 1652B, HP 16510A, and HP 16510B

These logic analyzers provide 1 k of memory depth with either 80 channels of 35 MHz state analysis (25 MHz state analysis for the HP 16510A) or 80 channels of 100 MHz timing analysis.

HP 1660A/61A/62A/63A

The HP 1660A/61A/62A/63A Logic Analyzers provide 4 k of memory depth with 136 channels (HP 1660A), 102 channels (HP 1661A), 68 channels (HP 1662A), or 34 channels (HP 1663A) of 100 MHz state analysis or 250 MHz timing analysis. These logic analyzers also support various combinations of mixed state/timing analysis.

HP 16511B

This logic analyzer combination provides 1 k of memory depth with either 160 channels of 35 MHz state analysis, or 80 channels of 35 MHz state analysis and 80 channels of 100 MHz timing analysis.

HP 16540A,D with one HP 16541A,D Expansion Card

This logic analyzer combination provides 4 k of memory depth (16 k with the D version) with up to 64 channels of 100 MHz state or timing analysis.

HP 16542A (Master Card and one expansion card)

This logic analyzer combination provides 1 M of memory depth with 32 channels of 100 MHz state or timing analysis.

HP 16550A

This logic analyzer provides 4 k of memory depth with 102 channels per card of 100 MHz state analysis or 250 MHz timing analysis. The logic analyzer will also support various combinations of mixed state/timing analysis.

How to Use This Manual

This manual is organized into three chapters and two appendices:

- Chapter 1 explains how to install and configure the HP E2423A Preprocessor Interface to perform measurements with the supported logic analyzers. It also contains tables listing the SCSI command sets for the different inverse assemblers.
- Chapter 2 provides reference information on the format specification and symbols configured by the HP E2423A software. It also provides information about the inverse assemblers and status encoding.
- Chapter 3 contains additional reference information including the characteristics and signal mapping for the HP E2423A Preprocessor Interface.
- Appendix A contains an overview of the Small Computer Systems Interface (SCSI). Additional information should be obtained from the appropriate standards organization for the SCSI Standard X3T9.2/86-109 Revision 10b.
- Appendix B contains information on troubleshooting problems or difficulties which may occur with the preprocessor interface.

Setting Up the HP E2423A

Introduction

This chapter explains how to install and configure the HP E2423A Preprocessor Interface to perform measurements with the supported logic analyzers.

Duplicating the Master Disk

Before you use the HP E2423A software, make a duplicate copy of the HP E2423A master disk. Then store the master disk and use the back-up copy to configure your logic analyzer. This will help prevent the possibility of losing or destroying the original files in the event the disk wears out, is damaged, or a file is accidentally deleted.

To make a duplicate copy, use the Duplicate Disk operation in the disk menu of your logic analyzer. For more information, refer to the reference manual for your logic analyzer.

HP 16500A Software Compatibility

The HP E2423A Preprocessor Interface requires HP 16500A system and module software version V04.01 or higher. If your software version is older than V04.01, load new HP 16500A system software with a version number of V04.01 or higher before loading the HP E2423A software.

Equipment Supplied

The HP E2423A SCSI Bus Preprocessor Interface consists of the following equipment:

- The preprocessor interface hardware, which includes the preprocessor interface circuit card.
- The inverse assembler software on a 3.5-inch disk.
- This user's guide.

Equipment Required

The minimum equipment required for SCSI Bus analysis consists of the following items:

- An HP 1650A (with memory upgrade), HP 1650B, HP 1652B, HP 1660A/61A/62A/63A, HP 16510A, HP 16510B, HP 16511B, HP 16540/16541A,D, HP 16542A, or HP 16550A Logic Analyzer.
- The HP E2423A Preprocessor Interface and Inverse Assembler.
- An additional cable to connect the HP E2423A to your SCSI bus system (see pages 1-4 and 1-5).

Installation Quick Reference

The following procedure describes the major steps required to perform measurements with the HP E2423A Preprocessor Interface. The page numbers listed in the various steps refer you to sections in this user's guide that offer more detailed information.

Caution

To prevent equipment damage, be sure to remove power from both the logic analyzer and the SCSI bus devices whenever the preprocessor interface or logic analyzer is being connected or disconnected.

1. Select the appropriate bus mode (Single-Ended or Differential), bus size (8-bit or 16-bit), and parity on the front panel of the HP E2423A (see page 1-3).
2. Connect the logic analyzer probes to the preprocessor interface board as listed in table 1-1 (see page 1-8 and 1-9).
3. Connect the HP E2423A SCSI Bus Preprocessor Interface to your SCSI bus system (see page 1-4).
4. Load the configuration file into the logic analyzer by loading the appropriate file from the flexible disk (see page 1-10).
5. Load the appropriate inverse assembler from the flexible disk (see page 1-11).

Setting Up the HP E2423A Front Panel

The HP E2423A has three switches on the front panel:

Bus Mode. Allows the user to test either a Single-Ended or a Differential Bus system. This switch setting must match the type of SCSI bus you are currently monitoring.

Bus Size. Allows the user to select either 8-bit or 16-bit bus size.

State Parity Check. The use of the parity bit is not mandatory on a SCSI bus system. This switch allows the user to switch off the parity check.



Excessive parity errors may appear on screen if parity is on with a system that does not use parity.

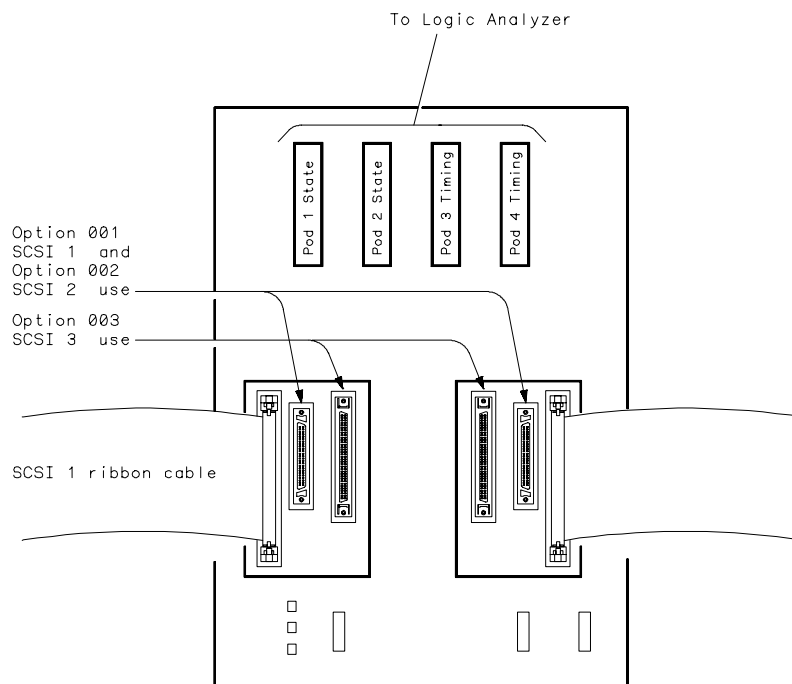

Figure 1-1. SCSI Preprocessor Interface Connectors

Connecting the HP E2423A to the SCSI Bus

The connectors on the HP E2423A are tied in parallel so that all the connectors and cable combinations can be used with a Single-Ended or Differential Bus. Also, there are always four connectors that are not used. These connectors may be used for additional analysis with an oscilloscope or other measurement device.

Figure 1-1 (previous page) shows the connectors on the SCSI Preprocessor Interface. There are three types of connectors on the front panel:

- Two 68-pin D-Shell shielded high-density type;
- Two 50-pin D-Shell shielded high-density type; and
- Two 50-pin (25-pin dual row, 0.1" spacing) nonshielded connectors (see Caution on next page).

You will always need at least one additional cable to connect the HP E2423A to your SCSI bus system. The following cable/connector options are available from your HP Sales/Service Office:

- E2423A Option 001 1 meter, 50-pin HD screw (m) to 50-pin LD bail (m). This option contains two of the cables described above.
- E2423A Option 002 1 meter, 50-pin HD screw (m) to 50-pin HD screw (m).
- E2423A Option 003 1 meter, 68-pin HD screw (m) to 68-pin HD screw (m).

If your SCSI Bus system requires different connectors or cables than those listed above, you will have to either make or obtain adapter cables. HP Direct Marketing (1-800-538-8787) has a variety of cables with different lengths, connectors, and locking technologies. They might have a cable which meets your requirements.

The following section provides instructions for connecting the cables to the SCSI bus and the HP E2423A Preprocessor Interface.

To connect the HP E2423A to the bus, daisy chain the connectors so both of the matching connectors are used together (see figure 1-2). This is accomplished by the following steps:

1. Turn off the power to the bus system and logic analyzer.
2. Disconnect one end of a cable from the bus system and connect it to one of the connectors on the HP E2423A.
3. Connect the optional or custom cable from the matching connector on the HP E2423A to your bus system.
4. Turn on the bus and logic analyzer.

You can also connect the HP E2423A to either end of your SCSI bus system. Remove the termination device from one end of the SCSI bus, and use the appropriate cable to connect the HP E2423A to the SCSI bus. Connect the termination device to the matching connector on the opposite side of the HP E2423A board.

Caution 

Some 50-pin ribbon cables have a connector clamped in the center of the cable for connecting devices to the SCSI bus with only a single connection. Do not use a center connector to connect the HP E2423A to the SCSI bus. Since the circuitry of the HP E2423A is part of the transmission line for the SCSI bus, a center connector will cause stub-length violations and the SCSI bus might not operate properly. You should always have a cable or termination device on both of the matching connectors on the HP E2423A.

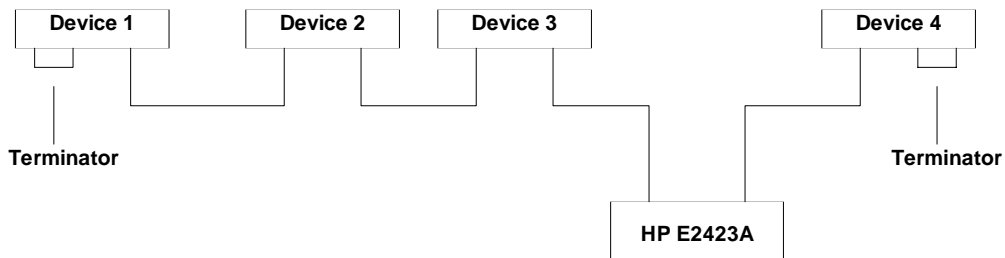

Figure 1-2. Connecting to the SCSI Bus

Connecting to the HP E2423A

Connect the logic analyzer probes to the cable connectors as listed in table 1-1. The column heads refer to the logic analyzer pods, while designations such as P1 refer to a connector on the preprocessor interface.

Figure 1-3 shows the relative locations of the logic analyzer cards.



HP 16542A with three or four Expansion Cards

The locations for the HP 16542A expansion cards, relative to the Master Card, depend on the number of expansion cards used. If one or two expansion cards are used, Card 1 is located above the Master Card and Card 2 is located below the Master Card. If three expansion cards are used, two of them are located above the Master Card and the third is located below the Master Card. When four expansion cards are used, they are located as shown in figure 1-3.

Table 1-1 shows the physical location and connections for a one-expansion-card system.

Power Up / Down Sequence

When powering up, the logic analyzer must be powered up first, and then the target system. The logic analyzer provides the power to the active circuits on the preprocessor interface; unpowered circuits may cause improper operation of the target system.

When powering down, the target system should be powered down first, and then the logic analyzer.

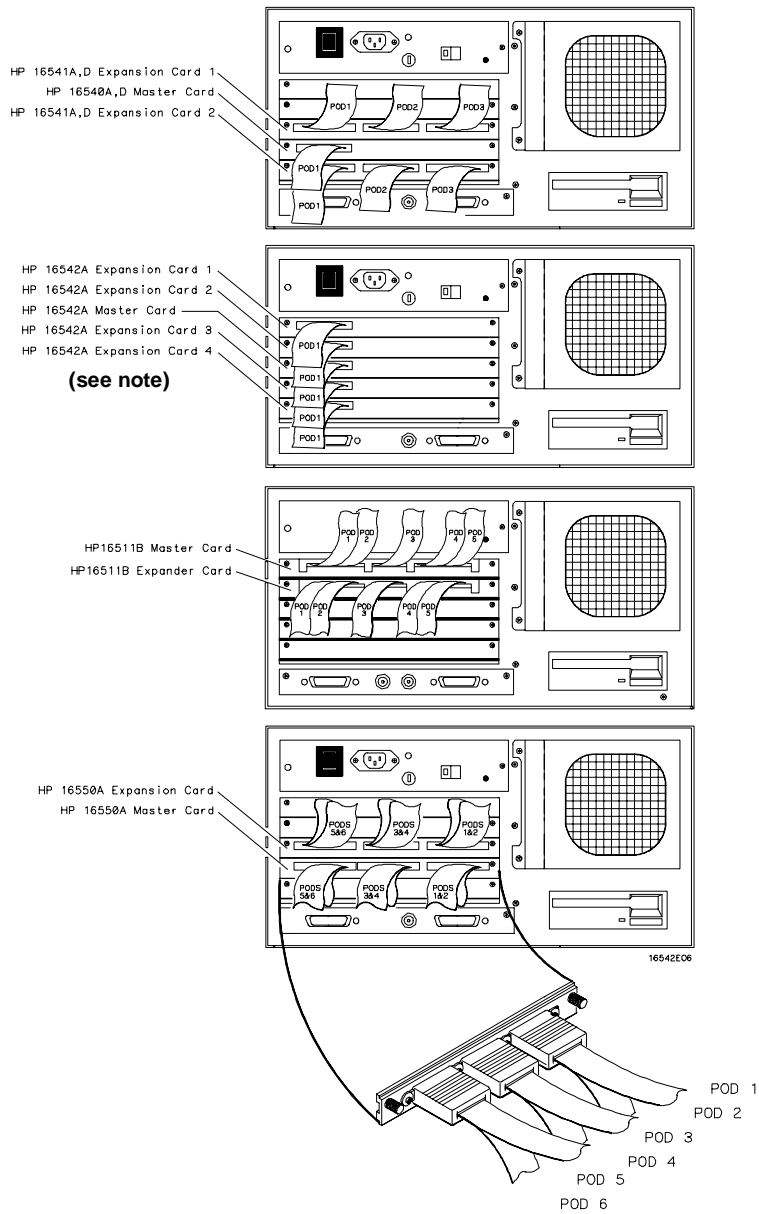

**Figure 1-3. Logic Analyzer Card Locations
 (relative locations, actual slots used may vary)**

**Table 1-1. Logic Analyzer Connections and Configuration Files
(HP 1650 series, HP 16510A/B, HP 16511B, HP 16540/16541A,D, HP 16550A)**

Logic Analyzer	File	Pod 6	Pod 5	Pod 4	Pod 3	Pod 2	Pod 1
HP 1650A/B, HP 1652B, HP 16510A/B	CSCSI2 state, timing		--	P4 Timing DATA	P3 Timing STAT	P2 State DATA	P1 State STAT clk ↓
HP 16511B Upper Card	DSCSI2 state, timing		--	--	--	P2 State DATA	P1 State STAT clk ↓
HP 16511B Lower Card			--	--	--	P4 Timing DATA	P3 Timing STAT
HP 16541A,D Exp. Card 1	ESCSI2ST state				P4 Timing DATA	P3 Timing STAT	P2 State DATA
HP 16540A,D Master Card	ESCSI2TM timing						P1 State STAT clk ↓
HP 16550A	FSCSI2 state, timing			P4 Timing DATA	P3 Timing STAT	P2 State DATA	P1 State STAT clk ↓

**Table 1-1. Logic Analyzer Connections and Configuration Files
(HP 1660 series, HP 16542A)**

Logic Analyzer	File	Pod 6	Pod 5	Pod 4	Pod 3	Pod 2	Pod 1
HP 16542A Exp. Card 1	ESCSI2ST state						P2 State DATA
HP 16542A Master Card							P1 State STAT clk ↓
HP 16542A Exp. Card 1	ESCSI2TM timing						P4 Timing DATA
HP 16542A Master Card							P3 Timing STAT
HP 1660A/ 61A/62A	FSCSI2 state, timing			P4 Timing DATA	P3 Timing STAT	P2 State DATA	P1 State STAT clk ↓
HP 1663A	FSCSI2 (state only)					P2 State DATA	P1 State STAT clk ↓

Setting Up the Analyzer from the Disk

The logic analyzer is configured for SCSI bus analysis by loading the appropriate configuration file. The configuration files also load the inverse assembler "ISCSIDIR." You can then load a different inverse assembler from the list on page 1-12.

For all logic analyzers except the HP 16540/16541A,D and HP 16542A, the same configuration file is used for state or timing analysis. For the HP 16540/16541A,D and HP 16542A, separate configuration files are provided for state and timing. To load the files:

1. Install the HP E2423A disk in the logic analyzer front disk drive.
2. Select one of the following menus:
 - For the HP 1650-series logic analyzers, select the I/O Disk Operations menu;
 - For the HP 16500-series and HP 1660-series logic analyzers, select the System Front Disk menu.
3. Configure the menu to "Load" the analyzer configuration from disk.
4. For HP 16500-series and HP 1660-series logic analyzers, select the appropriate module (such as "100/500 MHz LA" or "Analyzer") for the load.
5. Use the knob to select the appropriate configuration file (see table 1-1).
6. Execute the load operation to load the file into the logic analyzer.

Caution



DO NOT Autoscale the timing analyzer. The Autoscale operation will destroy the previously loaded configuration. The only way to recover the configuration after Autoscale is to reload it from the disk.

Loading an Inverse Assembler

The following section describes the different inverse assemblers available with the HP E2423A. To load a different inverse assembler after loading the configuration file:

1. Install the HP E2423A disk in the front disk drive of the logic analyzer.
2. Select one of the following menus:
 - For the HP 1650-series logic analyzers, select the I/O Disk Operations menu;
 - For the HP 16500-series and HP 1660-series logic analyzers, select the System Front Disk menu.
3. Configure the menu to "Load" the inverse assembler from disk.
4. For HP 16500-series and HP 1660-series logic analyzers, select the appropriate module (such as "100/500 MHz LA" or "Analyzer") for the load.
5. Use the knob to select the appropriate inverse assembler (see table 1-2, next page).
6. Execute the load operation to load the file into the logic analyzer.

Note



To properly load the HP E2423A inverse assemblers, Analyzer 1 of the logic analyzer must be on and configured as a State machine. If Analyzer 1 and 2 are on and configured as State machines, a field will appear on screen to allow you to select which analyzer to load the inverse assembler into. Load the HP E2423A inverse assembler into Analyzer 1.

Selecting the Correct Inverse Assembler

The HP E2423A has seven inverse assemblers available for SCSI Bus system analysis. The interpretation of the SCSI command set varies in each inverse assembler to match the applications of various device types. Only one inverse assembler can be used at a time. Table 1-2 lists the different inverse assemblers and the devices which are generally supported by the command sets.

There is a good possibility that your SCSI Bus system will be made up of several different device types, and each device type will interpret the commands differently. For example, a disk drive connected to a communication device contains two different device types. In this situation you may need to decide which inverse assembler will best fit your needs. To make it easier to select the appropriate inverse assembler, the commands for each device type are listed in tables 1-3 through 1-9. By comparing the commands for each inverse assembler, the most appropriate inverse assembler can be selected. The commands which are common to all devices are listed in normal type, and the commands which vary from device to device are listed in bold type.

Note



A different inverse assembler can be loaded into the logic analyzer without losing the accumulated data.

Table 1-2. Inverse Assemblers

Inverse Assembler	Devices Supported
ISCSIDIR	Direct Devices, Write Once Read Multiple Devices, and Optical Devices
ISCSISEQ	Sequential Devices like tape backup drives, and Scanner Devices
ISCSIPTR	Printers
ISCSIPRC	Processor Devices
ISCSIDSE	A special application which is used when there is a Sequential Access Device on the SCSI Bus that uses Group 0 (6 byte) commands which communicates with a Direct Access Device that uses Group 1 (10 byte) commands
ISCSIAMC	Automatic Media Changers, and Communication Devices
ISCSICDR	CD ROMs

Table 1-3. ISCSIDIR Commands

Group 0 Commands (6 byte)	Group 1 Commands (10 byte)	Group 2 Commands (10 byte)	Group 5 Commands (12 byte)
00 Test Unit Ready	24 Set Window	40 Change Definition	A5 Play Audio
01 Rezero	25 Read Capacity	41 Write Same	A6 Exchange Medium
03 Request Sense	28 Read	42 Read Sub-Channel	A8 Read
04 Format Unit	29 Read Generation	43 Read TOC	A9 Play Track
05 Read Block Limits	2A Write	44 Read Header	AA Write
07 Reassign Block	2B Seek	45 Play Audio	AC Erase
08 Read	2C Erase	47 Play Audio MSF	AE Write and Verify
0A Write	2D Read Update	48 Play Audio Track	AF Verify
0B Seek	Block	Index	B0 Search High
0F Read Reverse	2E Write and Verify	49 Play Audio Track	B1 Search Equal
10 Write Filemarks	2F Verify	Relative	B2 Search Low
11 Space	30 Search High	4B Pause/Resume	B3 Set Limits
12 Inquiry	31 Search =	4C Log Select	B5 Request Volume
13 Verify	32 Search Low	4D Log Sense	Element Address
14 Recovered Buffer	33 Set Limits	55 Mode Select	B6 Send Volume Tag
15 Mode Select	34 Pre-Fetch	5A Mode Sense	B7 Read Defect Data
16 Reserve	35 Flush Cache		B8 Read Element
17 Release	36 Lock/Unlock		Status
18 Copy	Cache		
19 Erase	37 Read Defect Data		
1A Mode Sense	38 Media Scan		
1B Start/Stop Unit	39 Compare		
1C Receive	3A Copy and Verify		
Diagnostics	3B Write Buffer		
1D Send Diagnostics	3C Read Buffer		
1E Prevent/Allow	3D Update Block		
Removal	3E Read Long		
1F Read Log	3F Write Long		

The commands in **bold** type vary from device to device; the commands in normal type are common to all devices.

Table 1-4. ISCSISEQ Commands

Group 0 Commands (6 byte)	Group 1 Commands (10 byte)	Group 2 Commands (10 byte)	Group 5 Commands (12 byte)
00 Test Unit Ready	24 Set Window	40 Change Definition	A5 Play Audio
01 Rewind	25 Get Window	41 Write Same	A6 Exchange Medium
03 Request Sense	28 Read	42 Read Sub-Channel	A8 Read
04 Format Unit	29 Read Generation	43 Read TOC	AA Write
05 Read Block Limits	2A Send	44 Read Header	AC Erase
07 Reassign Block	2B Locate	45 Play Audio	AE Write and Verify
08 Read	2C Erase	47 Play Audio MSF	AF Verify
0A Write	2D Read Update	48 Play Audio Track	B0 Search High
0B Seek	Block	Index	B1 Search Equal
0F Read Reverse	2E Write and Verify	49 Play Audio Track	B2 Search Low
10 Write Filemarks	2F Verify	Relative	B3 Set Limits
11 Space	30 Search High	4B Pause/Resume	B5 Request Volume
12 Inquiry	31 Object Position	4C Log Select	Element Address
13 Verify	32 Search Low	4D Log Sense	B6 Send Volume Tag
14 Recovered Buffer	33 Set Limits	55 Mode Select	B7 Read Defect Data
15 Mode Select	34 Read Position/Get	5A Mode Sense	B8 Read Element
16 Reserve Unit	Buffer		Status
17 Release Unit	35 Flush Cache		
18 Copy	36 Lock/Unlock		
19 Erase	Cache		
1A Mode Sense	37 Read Defect Data		
1B Load/Unload	38 Media Scan		
1C Receive	39 Compare		
Diagnostics	3A Copy and Verify		
1D Send Diagnostics	3B Write Buffer		
1E Prevent/Allow	3C Read Buffer		
Removal	3D Update Block		
1F Read Log	3E Read Long		
	3F Write Long		

The commands in **bold** type vary from device to device; the commands in normal type are common to all devices.

Table 1-5. ISCSIPTTR Commands

Group 0 Commands (6 byte)	Group 1 Commands (10 byte)	Group 2 Commands (10 byte)	Group 5 Commands (12 byte)
00 Test Unit Ready	24 Set Window	40 Change Definition	A5 Play Audio
01 Rezero	25 Read Capacity	41 Write Same	A6 Exchange Medium
03 Request Sense	28 Read	42 Read Sub-Channel	A8 Read
04 Format Unit	29 Read Generation	43 Read TOC	AA Write
05 Read Block Limits	2A Write	44 Read Header	AC Erase
07 Reassign Block	2B Seek	45 Play Audio	AE Write and Verify
08 Read	2C Erase	47 Play Audio MSF	AF Verify
0A Print	2D Read Update	48 Play Audio Track	B0 Search High
0B Slew and Print	Block	Index	B1 Search Equal
0F Read Reverse	2E Write and Verify	49 Play Audio Track	B2 Search Low
10 Sync Buffer	2F Verify	Relative	B3 Set Limits
11 Space	30 Search High	4B Pause/Resume	B5 Request Volume
12 Inquiry	31 Search =	4C Log Select	Element Address
13 Verify	32 Search Low	4D Log Sense	B6 Send Volume Tag
14 Recover Buffer	33 Set Limits	55 Mode Select	B7 Read Defect Data
Data	34 Pre-Fetch	5A Mode Sense	B8 Read Element
15 Mode Select	35 Flush Cache		Status
16 Reserve	36 Lock/Unlock		
17 Release	Cache		
18 Copy	37 Read Defect Data		
19 Erase	38 Media Scan		
1A Mode Sense	39 Compare		
1B Stop Print	3A Copy and Verify		
1C Receive	3B Write Buffer		
Diagnostics	3C Read Buffer		
1D Send Diagnostics	3D Update Block		
1E Prevent/Allow	3E Read Long		
Removal	3F Write Long		
1F Read Log			

The commands in **bold** type vary from device to device; the commands in normal type are common to all devices.

Table 1-6. ISCSIIRC Commands

Group 0 Commands (6 byte)	Group 1 Commands (10 byte)	Group 2 Commands (10 byte)	Group 5 Commands (12 byte)
00 Test Unit Ready	24 Set Window	40 Change Definition	A5 Play Audio
01 Rezero	25 Read Capacity	41 Write Same	A6 Exchange Medium
03 Request Sense	28 Read	42 Read Sub-Channel	A8 Read
04 Format Unit	29 Read Generation	43 Read TOC	AA Write
05 Read Block Limits	2A Write	44 Read Header	AC Erase
07 Reassign Block	2B Seek	45 Play Audio	AE Write and Verify
08 Receive	2C Erase	47 Play Audio MSF	AF Verify
0A Send	2D Read Update	48 Play Audio Track	B0 Search High
0B Seek	Block	Index	B1 Search Equal
0F Read Reverse	2E Write and Verify	49 Play Audio Track	B2 Search Low
10 Write Filemarks	2F Verify	Relative	B3 Set Limits
11 Space	30 Search High	4B Pause/Resume	B5 Request Volume
12 Inquiry	31 Search =	4C Log Select	Element Address
13 Verify	32 Search Low	4D Log Sense	B6 Send Volume Tag
14 Recovered Buffer	33 Set Limits	55 Mode Select	B7 Read Defect Data
15 Mode Select	34 Pre-Fetch	5A Mode Sense	B8 Read Element
16 Reserve	35 Flush Cache		Status
17 Release	36 Lock/Unlock		
18 Copy	Cache		
19 Erase	37 Read Defect Data		
1A Mode Sense	38 Media Scan		
1B Start/Stop	39 Compare		
1C Receive	3A Copy and Verify		
Diagnostics	3B Write Buffer		
1D Send Diagnostics	3C Read Buffer		
1E Prevent/Allow	3D Update Block		
Removal	3E Read Long		
1F Read Log	3F Write Long		

The commands in **bold** type vary from device to device; the commands in normal type are common to all devices.

Table 1-7. ISCSIDSE Commands

Group 0 Commands (6 byte)	Group 1 Commands (10 byte)	Group 2 Commands (10 byte)	Group 5 Commands (12 byte)
00 Test Unit Ready	24 Set Window	40 Change Definition	A5 Play Audio
01 Rewind	25 Read Capacity	41 Write Same	A6 Exchange Medium
03 Request Sense	28 Read	42 Read Sub-Channel	A8 Read
04 Format Unit	29 Read Generation	43 Read TOC	A9 Play Track
05 Read Block Limits	2A Write	44 Read Header	AA Write
07 Reassign Block	2B Seek	45 Play Audio	AC Erase
08 Read	2C Erase	47 Play Audio MSF	AE Write and Verify
0A Write	2D Read Update	48 Play Audio Track	AF Verify
0B Seek	Block	Index	B0 Search High
0F Read Reverse	2E Write and Verify	49 Play Audio Track	B1 Search Equal
10 Write Filemarks	2F Verify	Relative	B2 Search Low
11 Space	30 Search High	4B Pause/Resume	B3 Set Limits
12 Inquiry	31 Search =	4C Log Select	B5 Request Volume
13 Verify	32 Search Low	4D Log Sense	Element Address
14 Recovered Buffer	33 Set Limits	55 Mode Select	B6 Send Volume Tag
15 Mode Select	34 Pre-Fetch	5A Mode Sense	B7 Read Defect Data
16 Reserve Unit	35 Flush Cache		B8 Read Element
17 Release Unit	36 Lock/Unlock		Status
18 Copy	Cache		
19 Erase	37 Read Defect Data		
1A Mode Sense	38 Media Scan		
1B Load/Unload	39 Compare		
1C Receive	3A Copy and Verify		
Diagnostics	3B Write Buffer		
1D Send Diagnostics	3C Read Buffer		
1E Prevent/Allow	3D Update Block		
Removal	3E Read Long		
1F Read Log	3F Write Long		

The commands in **bold** type vary from device to device; the commands in normal type are common to all devices.

Table 1-8. ISCSIAMC Commands

Group 0 Commands (6 byte)	Group 1 Commands (10 byte)	Group 2 Commands (10 byte)	Group 5 Commands (12 byte)
00 Test Unit Ready	24 Set Window	40 Change Definition	A5 Move Medium
01 Rezero	25 Read Capacity	41 Write Same	A6 Exchange Medium
03 Request Sense	28 Get Message	42 Read Sub-Channel	A8 Get Message
04 Format Unit	29 Read Generation	43 Read TOC	AA Send Message
05 Read Block Limits	2A Send Message	44 Read Header	AC Erase
07 Initialize Element Status	2B Position to Element	45 Play Audio	AE Write and Verify
08 Read	2C Erase	47 Play Audio MSF	AF Verify
0A Write	2D Read Update Block	48 Play Audio Track Index	B0 Search High
0B Seek	2E Write and Verify	49 Play Audio Track Relative	B1 Search Equal
0F Read Reverse	2F Verify	4B Pause/Resume	B2 Search Low
10 Write Filemarks	30 Search High	4C Log Select	B3 Set Limits
11 Space	31 Search Equal	4D Log Sense	B5 Request Volume Element Address
12 Inquiry	32 Search Low	55 Mode Select	B6 Send Volume Tag
13 Verify	33 Set Limits	5A Mode Sense	B7 Read Defect Data
14 Recovered Buffer	34 Pre-Fetch		B8 Read Element Status
15 Mode Select	35 Flush Cache		
16 Reserve	36 Lock/Unlock Cache		
17 Release	37 Read Defect Data		
18 Copy	38 Media Scan		
19 Erase	39 Compare		
1A Mode Sense	3A Copy and Verify		
1B Start/Stop	3B Write Buffer		
1C Receive Diagnostics	3C Read Buffer		
1D Send Diagnostics	3D Update Block		
1E Prevent/Allow Removal	3E Read Long		
1F Read Log	3F Write Long		

The commands in **bold** type vary from device to device; the commands in normal type are common to all devices.

Table 1-9. ISCSICDR Commands

Group 0 Commands (6 byte)	Group 1 Commands (10 byte)	Group 2 Commands (10 byte)	Group 5 Commands (12 byte)
00 Test Unit Ready	24 Set Window	40 Change Definition	A5 Play Audio
01 Rezero	25 Read Capacity	41 Write Same	A6 Exchange Medium
03 Request Sense	28 Read	42 Read Sub-Channel	A8 Read
04 Format Unit	29 Read Generation	43 Read TOC	AA Write
05 Read Block Limits	2A Write	44 Read Header	AC Erase
07 Reassign Block	2B Seek X	45 Play Audio	AE Write and Verify
08 Read	2C Erase	47 Play Audio MSF	AF Verify
0A Write	2D Read Update Block	48 Play Audio Track Index	B0 Search High
0B Seek	2E Write and Verify	49 Play Audio Track Relative	B1 Search Equal
0F Read Reverse	2F Verify	4B Pause/Resume	B2 Search Low
10 Write Filemarks	30 Search High	4C Log Select	B3 Set Limits
11 Space	31 Search =	4D Log Sense	B5 Request Volume Element Address
12 Inquiry	32 Search Low	55 Mode Select	B6 Send Volume Tag
13 Verify	33 Set Limits	5A Mode Sense	B7 Read Defect Data
14 Recovered Buffer	34 Pre-Fetch		B8 Read Element Status
15 Mode Select	35 Flush Cache		
16 Reserve	36 Lock/Unlock Cache		
17 Release	37 Read Defect Data		
18 Copy	38 Media Scan		
19 Erase	39 Compare		
1A Mode Sense	3A Copy and Verify		
1B Start/Stop	3B Write Buffer		
1C Receive Diagnostics	3C Read Buffer		
1D Send Diagnostics	3D Update Block		
1E Prevent/Allow Removal	3E Read Long		
1F Read Log	3F Write Long		

The commands in **bold** type vary from device to device; the commands in normal type are common to all devices.

Analyzing the SCSI Bus

Introduction

This chapter provides reference information on the format specification and symbols configured by the HP E2423A software. It also provides information about the inverse assemblers and LED indicators.

Format Specification

The HP E2423A software sets up format specifications for the logic analyzer. There will be some slight differences in the displays, according to which logic analyzer you are using. For example, some of the logic analyzers do not have a Clock Period field.

The ADDR, DATA_, and DATA labels all contain the same information. The ADDR field is required by the inverse assembler software, but the information is not applicable for SCSI bus analysis. The DATA_ field shows the data in hexadecimal format in the Listing menu. The DATA field is decoded and shows the instruction in SCSI mnemonics.

Chapter 3 lists the SCSI bus signals for the HP E2423A and their corresponding lines to the logic analyzer.

Note

For those logic analyzers which have a Clock Period field (HP 1650A, HP 1650B, HP 1652B, HP 16510A, HP 16510B, and HP 16511B), the Clock Period field should remain in the current selection (> 60 ns) since the SCSI bus has bus cycle periods greater than 60 ns. For more information on the Clock Period field, refer to the reference manual for your logic analyzer.

Symbols and Labels

The configuration file sets up symbol tables on the logic analyzer. The tables contain alphanumeric values which identify data patterns.

Table 2-1 lists the bits assigned to the STAT and BUSIZE labels. Table 2-2 lists the symbols for the STAT label. Table 2-3 lists the symbols for the PHASE label.

Table 2-1. STAT Label and BUSIZE Label Bits

Bit	Signal	Description
0	I/O	This signal is true when data flows to the initiator and false when data flows to the target.
1	C/D	This signal is true when not in the data phase and false when in the data phase.
2	MSG	This signal is true when in the message phase and false when not in the message phase.
3	SEL	This signal is true during selection of target device.
4	BSY	This signal is true when the bus is in use and false when the bus is free or during selection of target device.
5	REQ	This signal is a handshake driven by the target device.
6	ACK	This signal is a handshake driven by the initiator.
7	ATN	This signal is used by the initiator to request an output phase.
8	RST	A true signal resets all devices on the bus.

Table 2-1. STAT Label and BUSIZE Label Bits (continued)

Bit	Signal	Description
9	LBUSPT	DBP Low byte bus parity bit (odd).
10	HBUSPT	DBP1 High byte bus parity bit (odd).
11	LPTYER	DBP Error. This bit is true when there is a low byte parity error.
12	HPTYER	DBP1 Error. This bit is true when there is a high byte parity error.
15 (BUSIZE Label)	BUSIZE	This bit sends the position of the Bus Size switch on the HP E2423A front panel.

Table 2-2. STAT Symbols

Symbol	Pattern												
RST BUS FREE	X	X	X	X	1	X	X	X	0	0	X	X	X
RESET	X	X	X	X	1	X	X	X	X	X	X	X	X
BUS FREE	X	X	X	X	0	X	X	X	0	0	X	X	X
ARBITRATION	X	X	X	X	0	0	0	0	1	1	0	0	0
ATTEN ARBIT	X	X	X	X	0	1	0	0	1	1	X	X	X
HL_PTY ERROR	1	1	X	X	0	X	X	X	X	X	X	X	X
L_PTY ERROR	0	1	X	X	0	X	X	X	X	X	X	X	X
H_PTY ERROR	1	0	X	X	0	X	X	X	X	X	X	X	X
SELECT	X	X	X	X	0	X	0	0	0	1	X	X	0
RESELECT	X	X	X	X	0	X	0	0	0	1	X	X	1
DATA OUT	X	X	X	X	0	X	X	X	1	0	0	0	0
DATA IN	X	X	X	X	0	X	X	X	1	0	0	0	1
COMMAND	X	X	X	X	0	X	X	X	1	0	0	1	0
STATUS	X	X	X	X	0	X	X	X	1	0	0	1	1
MSG OUT	X	X	X	X	0	X	X	X	1	0	1	1	0
MSG IN	X	X	X	X	0	X	X	X	1	0	1	1	1
DATA XFR	X	X	X	X	X	0	X	X	X	1	0	0	X

High Byte Parity Error
 Low Byte Parity Error
 High Byte Parity Bit
 Low Byte Parity Bit
 RESET

ATN
 ACK
 REQ
 BSY
 SEL
 MSG
 C/D
 I/O

Table 2-3. Phase Symbols

Symbol	Pattern
DATA OUT	0 0 0
DATA IN	0 0 1
COMMAND	0 1 0
STAT	0 1 1
PHASE 4	1 0 0
PHASE 5	1 0 1
MSG OUT	1 1 0
MSG IN	1 1 1

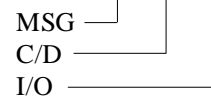

Accumulating Data

Touch RUN, and as soon as there is activity on the bus the logic analyzer will begin to accumulate data. The logic analyzer will continue to accumulate data and will display the data when the logic analyzer memory is full or when you touch STOP.



The logic analyzer will flash "Warning Slow Clock" when data is no longer being transmitted across the bus.

Listing Menu

Captured data is displayed as shown in figure 2-1. Additional labels may be viewed by rolling the display. The inverse assemblers are constructed so that the output lists the actual commands, status conditions, messages, and phases of the SCSI bus. The DATA_ label lists the data in hexadecimal format, and the DATA label lists the instructions in SCSI mnemonics.

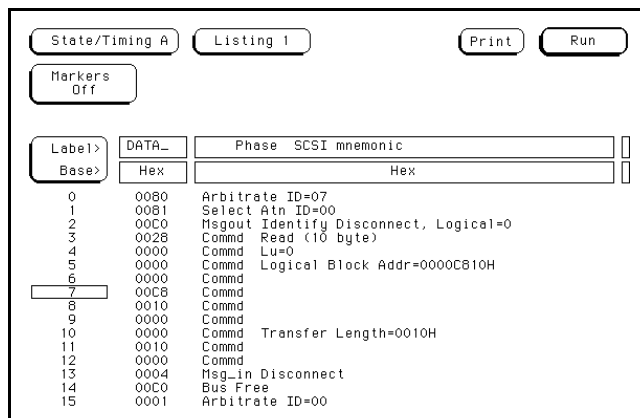

Label>	DATA_	Phase	SCSI mnemonic
Base>	Hex	Hex	Hex
0	0080		Arbitrate ID=07
1	0081		Select Atn ID=00
2	00C0		Msgout Identify Disconnect, Logical=0
3	0028		Commnd Read (10 byte)
4	0000		Commnd Lu=0
5	0000		Commnd Logical Block Addr=0000C810H
6	0000		Commnd
7	00C8		Commnd
8	0010		Commnd
9	0000		Commnd
10	0000		Commnd Transfer Length=0010H
11	0010		Commnd
12	0000		Commnd
13	0004		Msg_in Disconnect
14	00C0		Bus Free
15	0001		Arbitrate ID=00

Figure 2-1. Listing Menu

The SCSI Bus Inverse Assemblers

The HP E2423A has seven inverse assemblers available for use with various SCSI devices. These give you the flexibility of selecting the correct inverse assembler to decode any of the different device types that are called out in the SCSI Standard X3T9.2/86-109 Revision 10b. The command sets for the inverse assemblers are listed in tables 1-3 through 1-9.

The interpretation of the SCSI Command Sets vary in each inverse assembler to match the applications of various device types. Only one inverse assembler can be used at a time.

The HP E2423A inverse assemblers are designed to decode commands, messages, phases, and status conditions for 8-bit and 16-bit Single-Ended and Differential SCSI Bus systems. Rolling the screen up will inverse assemble the lines as they appear on the bottom of the screen. If you jump to another area of the screen by entering a new line number, simply roll the screen up to inverse assemble that block of memory.

Note



In order to correctly inverse assemble, the first byte of a command or message sequence must have been captured. The first byte does not have to be on the screen. If state capture starts or ends in the middle of a command or message byte sequence the inverse assembler will make an error in decoding that command or message.

Each time you inverse assemble a block of memory, the analyzer will keep that block in the inverse assembled condition. You can inverse assemble several different blocks in the analyzer memory, but the activity between those blocks will not be inverse assembled.

Interpreting Commands

The HP E2423A inverse assemblers decode six, ten, and twelve byte commands. The first line of the command lists the hexadecimal code of the command and the actual command. Blocks are decoded on the byte where they begin. The second line lists the logical unit for the selected peripheral device and lists the names of any bits that are true (logical 1). For example, byte 1 of a command often has bit 4 as DPO, bit 3 as FUA, and bit 1 as RelAdr. If all three of these bits were set as true, the following information would be displayed on the second line:

DPO FUA RelAdr

The last line lists the Flag and Link conditions when they are true (logical 1).

Interpreting Vendor Unique and Reserved Information

The SCSI Standard X3T9.2/86-109 Revision 10b has set aside some of the byte assignments for messages, status, and commands as either reserved for later definition or vendor unique. In the case of message and status, the HP E2423A inverse assembler listing will display the hexadecimal code for the information, list the information as either a message or status, and indicate if the information is vendor unique or reserved.

For commands, the HP E2423A inverse assembler listing will display the hexadecimal code for the command, list the information as a command, and indicate which group the command is from.

Interpreting Messages

The HP E2423A inverse assemblers decode the name of the message on the first line and indicate whether the message is going into the initiator (Msg_in) or out of the initiator (Msgout). The messages supported by the HP E2423A are:

- 00h Command Complete
- 01h Extended Message
- 02h Save Data Pointer
- 03h Restore Pointers
- 04h Disconnect
- 05h Initiator Detected Error
- 06h Abort
- 07h Message Reject
- 08h No Operation
- 09h Message Parity Error
- 0Ah Linked Command Complete
- 0Bh Linked Command Complete (with Flag)
- 0Ch Bus Device Reset
- 0Dh Abort Tag
- 0Eh Clear Queue
- 0Fh Initiate Recovery
- 10h Release Recovery
- 11h Terminate I/O Process
- 20h Simple Queue Tag
- 21h Head of Queue Tag
- 22h Ordered Queue Tag
- 23h Ignore Wide Residue
- 80h - FFh Identify

Note



Identify messages include a logic unit specifier.

Extended Messages. Most messages are only one byte long, but extended messages may be up to 256 bytes long. When the HP E2423A inverse assemblers decode an extended message, the name of the message is shown on the first line along with "xmsg" to identify it as an extended message. Also, Msg_in or Msgout appears on the first line to indicate whether the message is going into the initiator or out of the initiator.

Each extended message will also include information specific to that message on the first line:

- Modify Data Pointer includes the message arguments;
- Synchronous Data Transfer Request includes the transfer period and offset as a hexadecimal byte;
- Extended Identify includes a logical unit number;
- Wide Data Transfer Request includes the transfer width as a hexadecimal byte.

The next line shows the length of the extended message in hexadecimal, and the third line lists the message code. For a complete description of specific extended messages, refer to the SCSI Standard X3T9.2/86-109 Revision 10b, Section 5.5.

Interpreting Status

The HP E2423A inverse assemblers decode all status conditions. Since status is only one byte, the actual status is listed following the status identifier. The status values supported by the HP E2423A inverse assemblers are:

- Good
- Check Condition
- Condition Met
- Busy
- Intermediate
- Intermediate/Condition Met
- Reservation Conflict
- Command Terminated
- Queue Full

Interpreting Data Since the data going across the bus is totally dependent and defined by the user, the HP E2423A inverse assemblers can only indicate whether the data is going into the initiator (Dat_in) or out of the initiator (Datout). The rest of the data information cannot be interpreted by the HP E2423A.

Arbitration, Select, and Reselect Phases When an Arbitration, Select, or Reselect phase occurs, the HP E2423A inverse assemblers identify the phase and list the interface device that is involved. For example:

Arbitr ID= 3

indicates that interface device 3 has started an Arbitration phase.

Attention, Reset and Bus Free The HP E2423A inverse assemblers will display the Attention bit (Atn) for every state in which the Attention bit is asserted true.

The Reset bit (Rst) will be displayed for every state where it is asserted true. If the Reset bit becomes true while the SCSI bus is in the Bus Free state, the state is displayed as "Reset Bus Free." Otherwise, a true Reset bit is displayed as "Reset."

The Bus Free state is displayed as "Bus Free." If a Reset occurs while the bus is free, the state is displayed as "Reset Bus Free."

Parity Error When the inverse assembler detects a parity error, it stops inverse assembly until the next valid state.

If a parity error is detected on the first line of a command, status, or message, then that line is not decoded. If the parity error is detected after the first line, the command or message is decoded.

Note 

If parity is selected for the HP E2423A and parity is not used in your SCSI Bus system, excess parity errors will appear on the listing display.

The Trace Menu

The configuration files provided with the HP E2423A set up the Trace Specification so that only five lines of data are stored for each data transfer. Figure 2-2 shows the Trace Specification. The events which occur in sequences 1, 2, and 3 are as follows:



In the following descriptions, Phases refers to the type of information being transferred (data or commands), while State refers to a single line of information on the logic analyzer screen.

1. Sequence 1 defines the starting point of state storage in the logic analyzer memory. 'While storing "no state"' indicates that storage will not begin until the specified trigger. If this is changed to 'While storing "anystate"', the logic analyzer will use half of the memory to store pretrigger states and half of the memory to store posttrigger states.
2. Sequence 2 stores the states after the trigger. However, it will only store five consecutive data phases. After the fifth data phase it moves to sequence 3. You can change the number of data phases that are stored by changing the 5 to the desired number.
3. Sequence 3 filters out the data phases while it looks for a non data phase. When a non data phase occurs, it stores that phase and transfers control back to sequence 2.

You can count the number of data phases that are filtered out in sequence 3 by setting the Count window to "STATES." The number of filtered data phases will be displayed on the first line after the five data states. The time lapse between states can be observed by setting the Count window to "TIME." However, the STATES and TIME selections reduce the state storage memory by one half.

For further information on changing the Trace menu specifications, refer to your logic analyzer operating manual.

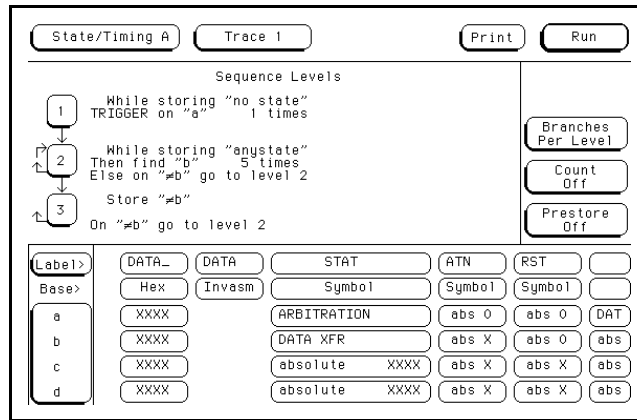

Figure 2-2. Trace Screen

LED Indicators

Three LED light bars of 10 LEDs each are used as front panel indicators of the static condition of the bus.

- One group for Data; and
- One group for Status.

The following LEDs are provided for Data: data bits 0 through 15, two Parity, and two Parity Error. Parity Error is not one of the SCSI signal lines; it is generated by internal hardware of the preprocessor interface when a parity error occurs and the front panel State Parity Error switch is on.

Nine SCSI Status lines are shown on the other LED light bar. These include I/O, C/D, MSG, and the SCSI phases.

Additional Information

Introduction

This chapter contains additional reference information including the characteristics and signal mapping for the HP E2423A Preprocessor Interface.

Characteristics

The following characteristics are not specifications, but are typical operating characteristics for the HP E2423A Preprocessor Interface. These characteristics are included as additional information for the user.

Bus Compatibility: 8-bit and 16-bit Single-Ended and Differential SCSI Bus systems containing any of the device types specified in the SCSI Standard X3T9.2/86-109 Revision 10b.

SCSI Standard Supported: X3T9.2/86-109 Revision 10b.

SCSI Device Types Supported: Direct Access Devices, Write Once Read Multiple Devices, and Optical Devices (ISCSIDIR)
Sequential Devices (ISCSISEQ)
Printers (ISCSIPTR)
Processor Devices (ISCSIPRC)
Sequential Devices using Group 0 (6 byte) commands communicating with a Direct Access Device using Group 1 (10 byte) commands (ISCSIDSE)
Automatic Media Changers (ISCSIAMC)
CD ROM Devices (ISCSICDR)

Accessories Required: Adapter cables may be required for some SCSI bus systems

Available Options:

Option 001	1 meter, 50-pin HD screw (m) to 50-pin LD bail (m). This option consists of two cables.
Option 002	1 meter, 50-pin HD screw (m) to 50-pin HD screw (m).
Option 003	1 meter, 68-pin HD screw (m) to 68-pin HD screw (m).

Maximum Bus Speeds: 10 MHz

Timing Specifications: Meets all timing specifications set forth in SCSI ANSI Specification X3T9.2/86-109, Revision 10b.

Signal Line Loading: 0.4 mA TTL Low at 0.5 V.

Bus Cycles Interpreted: Arbitration
Select/Reselect
Commands
Messages
Status
Reset
Bus Free

Power Requirements: 0.80 A at + 5 Vdc max, supplied by the logic analyzer.

Logic Analyzer Required: HP 1650A (with HP 10449A memory upgrade), HP 1650B, HP 1652B, HP 1660A/61A/62A/63A, HP 16510A, HP 16510B, HP 16511B, HP 16540/16541A,D (Master Card and one expansion card), HP 16542A (Master Card and one expansion card), or HP 16550A.

Number of Probes Used: Two for state or timing, four for both.

Environmental

Temperature: Operating: 0 to + 55 degrees C (+ 32 to + 131 degrees F)
Nonoperating: -40 to + 75 degrees C (-40 to + 167 degrees F)

Altitude: Operating: 4600 m (15,000 ft)
Nonoperating: 15,300 m (50,000 ft)

Humidity: To 90% noncondensing. Avoid sudden, extreme temperature changes which could cause condensation within the instrument.

Clocking

The SCSI bus signals are sampled and routed to the logic analyzer so that all signals for a bus cycle are sent to the logic analyzer at the same time. Since the SCSI bus signals become active at different times throughout the bus cycle, some of the signals are latched by the preprocessor interface, while others are connected directly to the logic analyzer. When the logic analyzer is clocked, the latched and straight through signals are all read at the same time.

The 16 Data bus lines plus the two Parity bits and the two Parity Error bits that are generated by the preprocessor interface hardware are sampled by internal latches. The I/O, C/D and MSG signals are latched internally at the same time. The outputs of these latches are then read at a later time when the logic analyzer receives its clock.

The Attention, Reset, Busy and Select signals are not latched internally but are connected directly to the logic analyzer. These signals are sampled after the signals listed in the previous paragraph. Figure 3-1 shows the latching and clocking cycle for the HP E2423A.

Arbitration Phase. The SCSI bus is sampled by the HP E2423A Preprocessor Interface 800 ns after both BUSY and SELECT become active. The logic analyzer is clocked 40 ns after these signals are sampled.

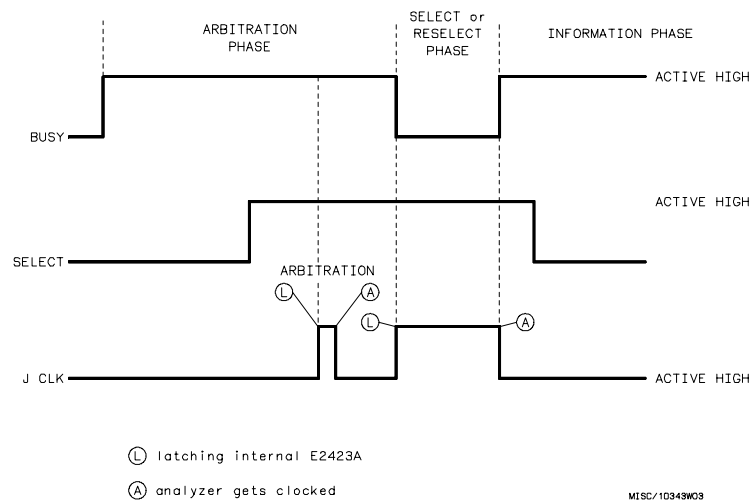

Figure 3-1. HP E2423A Latching and Clocking Timing

Select and Reselect Phase. Internal latching takes place at the beginning of the select phase when BUSY becomes negated. The logic analyzer is clocked when BUSY becomes active at the end of the SELECT phase.

Information Phases. When the SCSI bus is transferring data and instructions, the handshake lines determine the clock. Figure 3-2 and table 3-1 show the latching and clocking for the information phase.

Command, Status, and Message Phases. Internal latching takes place when the Request handshake goes active. The logic analyzer is clocked when the Acknowledge line goes inactive (negated).

Data In Phase. Request is the only controlling signal for the Data In phase. Internal latching takes place on the active edge of Request. The analyzer is clocked on the negating edge of Request.

Data Out Phase. Acknowledge is the only controlling signal for the Data Out phase. Internal latching takes place on the active edge of Acknowledge. The analyzer is clocked on the negating edge of Acknowledge.

Bus Free. The E2423A waits for 400 ns after both BUSY and SELECT are negated. Then the bus is sampled. First a latching operation takes place, and 40 ns later the logic analyzer is clocked. If RESET is active, a Reset Bus Free is displayed on the analyzer screen. Otherwise only a Bus Free is displayed on screen.

Reset. The RESET signal is sampled along with all other signals during the bus active phases. If in the Bus Free condition and a reset takes place, a latching operation takes place with a logic analyzer clock following 40 ns later.

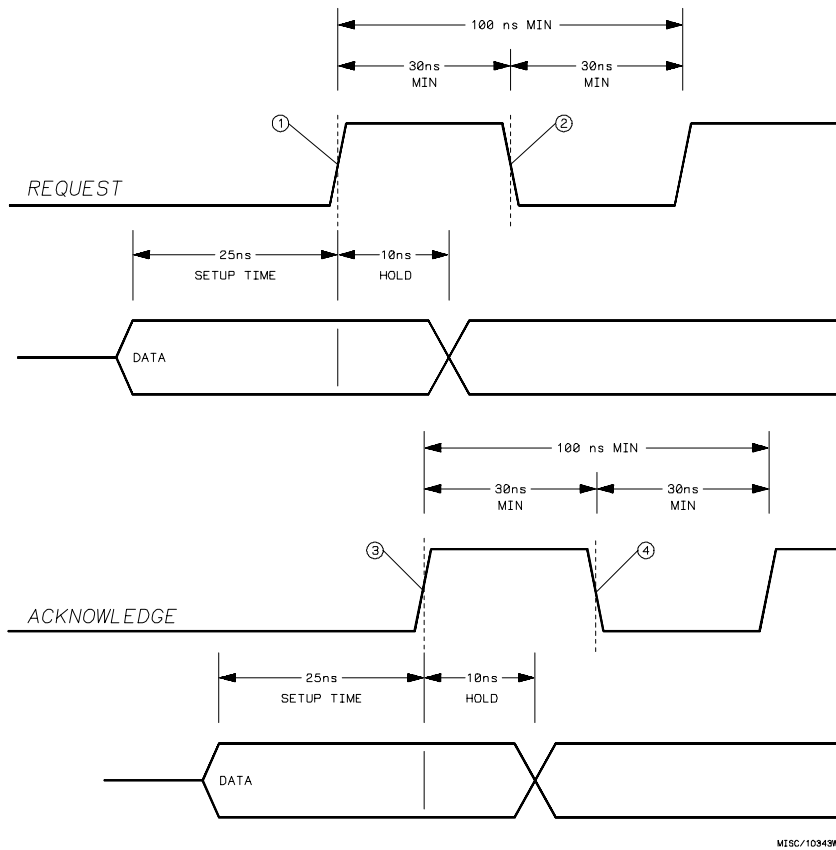

Figure 3-2. Request and Acknowledge Timing

Table 3-1. Latching and Clocking for Information Phases

Phase	Internal Latching	Analyzer Clocked
Command Status MSG	1 (see drawing above)	4
Data In	1	2
Data Out	3	4

Interface Description

The HP E2423A provides a complete mechanical and electrical interface between the logic analyzer and an 8-bit or 16-bit SCSI bus system. This interface allows the logic analyzer to capture and decode all of the activities on the SCSI bus. The SCSI bus is observed by high impedance comparators on the HP E2423A. The outputs of these comparators go directly to the logic analyzer for timing analysis.

For state analysis, the SCSI bus phase activities are decoded by the Phase Detection Logic. The logic analyzer clock is sent out at the correct times to capture the data.

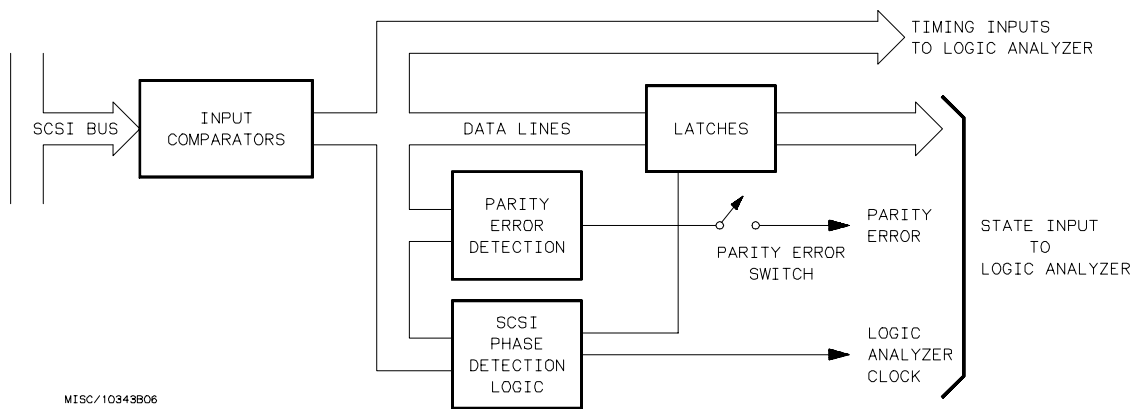

Figure 3-3. HP E2423A Block Diagram

SCSI Bus Signal to HP E2423A Connector Mapping

Note



The following table describes the electrical interconnections implemented with the HP E2423A Preprocessor Interface. Since the pods on the logic analyzer may be numbered differently than the other logic analyzers, refer to table 1-1 to correlate the pod numbers.

The interconnections implemented for state analysis with the HP E2423A are not direct interconnections. The HP E2423A Preprocessor Interface places digital circuitry between SCSI bus signals and the logic analyzer input on pods 1 and 2. For timing analysis, the interconnections are straight through.

Table 3-2. Logic Analyzer to SCSI Signal Connections

Preprocessor Pod	Logic Analyzer Probe	SCSI Bus Signal	Analysis Type
1	0	I/O	State
1	1	C/D	State
1	2	MSG	State
1	3	SEL	State
1	4	BSY	State
1	5	REQ	State
1	6	ACK	State
1	7	ATN	State
1	8	RESET	State
1	9	LBUSPT	State
1	10	HBUSPT	State
1	11	LPTYER	State
1	12	HPTYER	State
1	13	(Blank)	State
1	14	(Blank)	State
1	15	BUSIZE	State
2	0	Data 0	State
2	1	Data 1	State
2	2	Data 2	State
2	3	Data 3	State
2	4	Data 4	State
2	5	Data 5	State
2	6	Data 6	State
2	7	Data 7	State

Table 3-2. Logic Analyzer to SCSI Signal Connections (continued)

Preprocessor Pod	Logic Analyzer Probe	SCSI Bus Signal	Analysis Type
2	8	Data 8	State
2	9	Data 9	State
2	10	Data 10	State
2	11	Data 11	State
2	12	Data 12	State
2	13	Data 13	State
2	14	Data 14	State
2	15	Data 15	State
3	0	I/O	Timing
3	1	C/D	Timing
3	2	MSG	Timing
3	3	SEL	Timing
3	4	BSY	Timing
3	5	REQ	Timing
3	6	ACK	Timing
3	7	ATN	Timing
3	8	RESET	Timing
3	9	LBUSPT	Timing
3	10	HBUSPT	Timing
3	11	LPTYER	Timing
3	12	HPTYER	Timing
3	13	(Blank)	Timing
3	14	(Blank)	Timing
3	15	BUSIZE	Timing

Table 3-2. Logic Analyzer to SCSI Signal Connections (continued)

Preprocessor Pod	Logic Analyzer Probe	SCSI Bus Signal	Analysis Type
4	0	Data 0	Timing
4	1	Data 1	Timing
4	2	Data 2	Timing
4	3	Data 3	Timing
4	4	Data 4	Timing
4	5	Data 5	Timing
4	6	Data 6	Timing
4	7	Data 7	Timing
4	8	Data 8	Timing
4	9	Data 9	Timing
4	10	Data 10	Timing
4	11	Data 11	Timing
4	12	Data 12	Timing
4	13	Data 13	Timing
4	14	Data 14	Timing
4	15	Data 15	Timing

Servicing

The repair strategy for the HP E2423A is board replacement. However, table 3-3 lists some mechanical parts that may be replaced if they are damaged or lost. Contact your nearest Hewlett-Packard Sales/Service Office for further information on servicing the board.

Exchange assemblies are available when a repairable assembly is returned to Hewlett-Packard. These assemblies have been set up on the "Exchange Assembly" program. This allows you to exchange a faulty assembly with one that has been repaired, calibrated, and performance verified by the factory. The cost is significantly less than that of a new assembly.

Table 3-3. Replaceable Parts

HP Part Number	Description
E2423-69501	Exchange Board/Cable Assembly
E2423-66501	Circuit Board/Cable Assembly
E2423-68702	Inverse Assembler Disk Pouch
5062-3383	Option 001 Cable (SCSI One, 8-bit)
8120-5548	Option 002 Cable (SCSI Two, 8-bit)
A1658-62018	Option 003 Cable (SCSI Three, 16-bit)

For a complete description of the optional cables listed in table 3-3, see page 1-4. These cables can be ordered from your Hewlett-Packard Sales/Service Office or from HP Direct Marketing (1-800-538-8787). HP Direct Marketing also has a variety of cables which might meet an unusual connector requirement.

SCSI Overview

Introduction

The Small Computer Systems Interface (SCSI) is a standard that may be used for fast transfers of data between computers and peripherals. The standard hardware of the 8-bit or 16-bit SCSI Bus is a 50- or 68-wire cable that interconnects up to a maximum of 8 or 16 devices on the bus. By definition there are 8 or 16 data lines with one or two parity bits. Parity is odd and the use of the parity is optional for SCSI.

There are two SCSI Bus Types:

- Single-Ended; and
- Differential.

The Single-Ended bus runs at TTL levels with a logical 1 (active) being a low level on the bus. The Differential bus uses two lines per signal with the lines moving between approximately 2 and 3 volts.

Each device on the bus is assigned a device number of 0 through 15. If there is a condition of more than one device asking for the bus at one time, the highest priority device gets the bus. The device priority is in the following order, with 7 the highest and 8 the lowest priority: 7, 6, 5, 4, 3, 2, 1, 0, 15, 14, 13, 12, 11, 10, 9, 8. Each device is assigned one line on the data bus for a device ID.

With SCSI, the host computer is not the bus controller. The device that the host calls is the bus controller. Most often this is a mass storage device.

The host computer is called the INITIATOR and the device that the host calls on the bus is called the TARGET.

SCSI Status Lines

Nine status lines are defined by the SCSI Standard X3T9.2/86-109 Revision 10b:

- I/O;
- C/D;
- MESSAGE;
- BUSY;
- SELECT;
- REQUEST;
- ACKNOWLEDGE;
- ATTENTION; and
- RESET.

There are also ten phases defined by the SCSI standard. These are not timing phases, but conditions of the bus action. They are:

- ARBITRATION;
- SELECT;
- RESELECT;
- DATA OUT;
- DATA IN;
- COMMAND;
- STATUS;
- MESSAGE OUT;
- MESSAGE IN; and
- BUS FREE.

I/O, C/D, and Message. The I/O, C/D, and Message Status lines define six of these phases of the SCSI Bus (see table A-1).

Busy. The bus is considered free when the Busy and Select lines are inactive. An initiator asks for the bus by driving Busy active and driving its identification (ID) line active on the data lines. If no other device with a higher priority drives the line, then the initiator signals that it has the bus by driving Select active. This is called the Arbitration Phase. The parity bit is not tested in the Arbitration Phase.

Select. After the initiator has the bus and drives Select active it then drives the ID line of the device it is calling (the target) active and releases Busy. The device being called responds by driving Busy active. The Initiator at this point releases Select. Select is not used for any other purpose. This is called the Select or Reselect phase. Reselect is when the Target is calling the Initiator. This is accomplished by driving the I/O line active after the Arbitration phase. The target device is now in control of the Busy line and is the only device that can release the bus. At this point the bus is ready to transfer information.

Request and Acknowledge. These are handshake lines. Request is driven by the target and Acknowledge is driven by the initiator. These handshakes are used to transfer information between devices in either direction. The information that is transferred between devices is enveloped in one of six phases that are determined by the setting of the three lines: I/O, C/D, and Message (see table A-1).

Attention. Since the target is in control of the bus lines, the Attention line (Atn) is used by the Initiator to request to send a Message or a Command.

Reset. This is used to reset the bus to a Bus Free State and reset the devices that are on the bus.



The SCSI standard includes over 82 commands, 9 Status conditions, and 25 Messages in its instruction set and has room for more to be added. The bus is defined to be capable of transferring 10 Megabytes per second using an 8-bit bus or 20 Megabytes per second using a 16-bit bus.

Table A-1. Phases

Message	C/D	I/O	Name of Phase
0	0	0	Data Out
0	0	1	Data In
0	1	0	Command
0	1	1	Status
1	0	0	Phase 4
1	0	1	Phase 5
1	1	0	Message Out
1	1	1	Message In

Troubleshooting

If you encounter difficulties while making measurements, use this section to guide you through some possible solutions. Each heading lists a problem you may encounter, along with some possible solutions. Error messages which may appear on the logic analyzer are listed below in quotes ". Symptoms are listed without quotes.

If you are still having difficulties after trying the suggestions below, please contact your local Hewlett-Packard service center for additional assistance.

"Slow or Missing Clock"

This error message might occur if the logic analyzer cards are not firmly seated in the HP 16500/16501 frame. Ensure that the cards are firmly seated.

This error might also occur if the target system is not running properly. Ensure that the target system is on and operating properly.

If the error message persists, check that the logic analyzer pods are connected to the proper connectors, as listed in table 1-1.

For HP 1650A and HP 16510A Logic Analyzers, check the preprocessor interface power fuse in the logic analyzer.

No Activity on Activity Indicators

On the HP 1650A, HP 1651A, and HP 16510A Logic Analyzers if there is no activity the fuse which allows power to the preprocessor interface is probably blown. Check the fuse in the logic analyzer. On the other logic analyzers, if there is no activity, one of the cables, board connections, or preprocessor interface connections is probably loose. Check all connections.

Slow Clock If you have the preprocessor interface hooked up and running and observe a slow clock or no activity, the + 5 V supply coming from the analyzer may not be getting to the preprocessor interface.

To check the + 5 V supply coming from the analyzer, disconnect one of the logic analyzer cables from the HP E2423A and measure across pins 1 and 2 or pins 39 and 40 (see figure B-1).

- If + 5 V isn't observed across these pins, check the internal preprocessor fuse or current limiting circuit on the logic analyzer. For information on checking this fuse or circuit, refer to the service manual for your logic analyzer.
- If + 5 V is observed across these pins and you feel confident that the + 5 V is getting to the preprocessor interface, contact your nearest Hewlett-Packard Sales/Service Office for information on servicing the board.

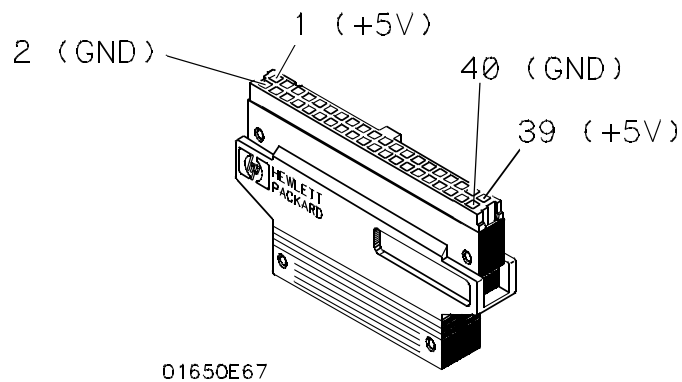

Figure B-1. Pinout of the Logic Analyzer Cable

"No Configuration File Loaded"

Verify that the appropriate module has been selected from the Load {module} from File {filename} in the HP 16500 disk operation menu. Selecting Load {All} will cause incorrect operation when loading most preprocessor interface configuration files.

"Selected File is Incompatible"

The logic analyzer displays this message if you try to load a configuration file for the wrong module. Ensure that you are loading the appropriate configuration file for your logic analyzer.

". . . Inverse Assembler Not Found"

This error occurs if you rename or delete the inverse assembler file that is attached to the configuration file. Ensure that the inverse assembler file is not renamed or deleted.

No Inverse Assembly

Verify that the inverse assembler has been synchronized by placing an opcode at the top of the display (not at the input cursor) and pressing the Invasm key (see "Inverse Assembler" in Chapter 2).

Incorrect Inverse Assembly

This problem is usually caused by a hardware problem in the target system. A locked status line will often cause incorrect or incomplete inverse assembly.

- Check the activity indicators for status lines locked in a high or low state.
- Verify that the STAT and DATA format labels have not been modified from their default values. These labels must remain as they are configured by the configuration file.
- Verify that storage qualification has not excluded storage of all the needed opcodes and operands.

"State Clock Violates Overdrive Specification"

At least one 16-channel pod in the state analysis measurement stored a different number of states before trigger than the other pods. This is usually caused by sending a clocking signal to the state analyzer that does not meet all of the specified conditions, such as minimum period, minimum pulse width, or minimum amplitude. Poor pulse shaping could also cause this problem.

Note 

The error message "State Clock Violates Overdrive Specification" should only occur for HP 1650A,B, HP 1652B, HP 16510A,B, and HP 16511B Logic Analyzers with the Clock Period field set to < 60 ns. If this error message is observed with the Clock Period set to > 60 ns, you may have a faulty logic analyzer. If a failure is suspected in your logic analyzer, contact your nearest Hewlett-Packard Sales/Service Office for information on servicing the instrument.

Unwanted Triggers

Unwanted triggers can be caused by unexecuted prefetches. Add the prefetch queue depth to the trigger address to avoid this problem.

"Waiting for Trigger" If a trigger pattern is specified, this message indicates that the specified trigger pattern did not occur. Verify that the triggering pattern is correctly set.

If a "don't care" trigger condition is set, this message on an HP 1650A,B, HP 1652B, or HP 16510A,B Logic Analyzer indicates that the pattern duration is probably set to less than (<) instead of greater than (>). Since a "don't care" pattern is always true, the "less than" condition is never satisfied. Set the trace menu correctly for the measurement that is desired.

Intermittent Data Errors This problem is usually caused by incorrect signal levels. Adjust the threshold level of the data pod. Use an oscilloscope to check the signal integrity of the data lines, as needed.

Bent Pins Bent pins on the preprocessor interface, pin protectors, or adapters can cause system errors or inverse assembly errors. Ensure all pins are properly aligned and making contact.

"Time from Arm Greater Than 41.93 ms." The state/timing analyzers have a counter to keep track of the time from when an analyzer is armed to when it triggers. The width and clock rate of this counter allow it to count for up to 41.93 ms before it overflows. Once the counter has overflowed, the system does not have the data it needs to calculate the time between module triggers. The system must know this time to be able to display data from multiple modules on a single screen.

No Setup/Hold Field on Format Screen The HP 16540/16541A,D or HP 16542A Logic Analyzer cards are not calibrated. Refer to your logic analyzer reference manual for procedures to calibrate the cards.

"Default Calibration Factors Loaded" (16540/41/42) The default calibration file for the logic analyzer was loaded. The logic analyzer must be calibrated when using HP 16540A,D, HP 16541A,D or HP 16542A cards. Refer to your logic analyzer manual for procedures to calibrate the master clocking system, and ensure that the "cal factors" file is saved.